



Blow Molding Industry

# Preform/Bottle Eject Slide

ML#316228 | 'S' Style Universal® & Matrix® Spare Component

## BENEFITS

- Direct drop in on 'S' style Universal® and Matrix® machines
- High speed
- Integral travel stops for controlled eject
- Dual durometer shock pads for kinetic energy control and longer life

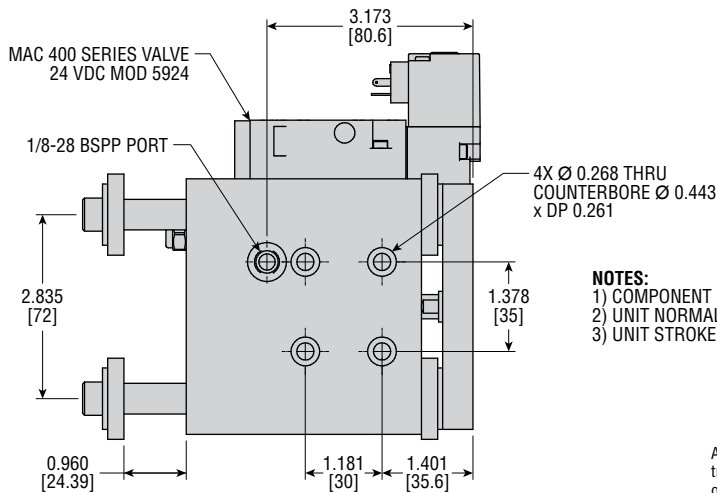
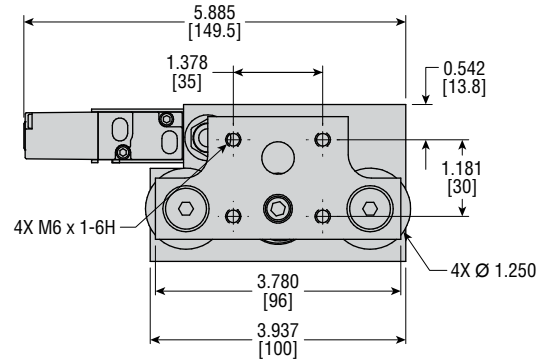
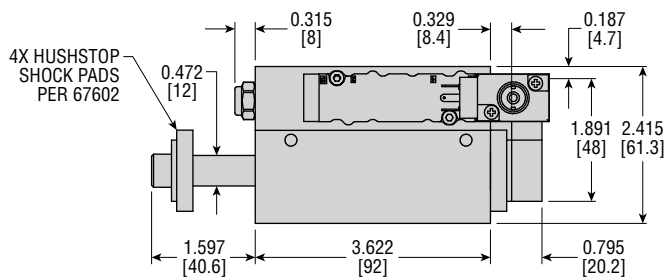
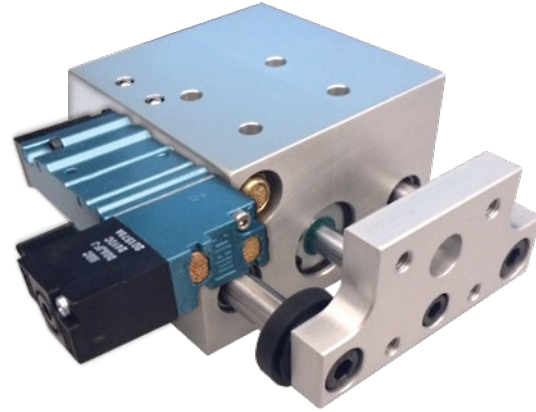

- NOTES:**
- 1) COMPONENT FOR 'S' STYLE UNIVERSAL® BOTTLE/PREFORM EJECT SLIDE
  - 2) UNIT NORMALLY EXTENDED. ENERGIZING VALVE RETRACTS SLIDE.
  - 3) UNIT STROKE = 0.960 ±0.030 [24.4 ±0.75]

Any marks or names referenced herein are either registered trademarks or trademarks of their respective owners. No association with or endorsement of any company, organization, or product is intended or should be inferred.

All dimensions are reference only unless specifically tolerated.

© Copyright 2018, by PHD, Inc. All Rights Reserved. Printed in the U.S.A.

CP316228



PHD is a member of the MAC Distributor Network



SOLUTIONS FOR INDUSTRIAL AUTOMATION

www.phdinc.com