

phd[®] SERIES PNC44/55 CLAMP SEAL INSTALLATION

INSTALLATION PROCEDURE:

- 1) Apply Magna-Lube G lubricant to each area separately: piston O.D. and seal groove, piston rod O.D., rod seal groove, cylinder bore, piston seal, rod seal, cap seal groove, and cap seal.
- 2) Install rod seal into rod seal groove in body (note seal orientation), piston seal into piston seal groove, and cap seal into cap seal groove.
- 3) Place bullet onto end of piston rod as shown and push through rod seal. Remove bullet after assembly of piston into body.
- 4) Apply Loctite 242 to piston SHCS and install piston SHCS through piston and thread into cam (not shown). Tighten to specified torque. (Piston, piston SHCS, and cam ordered separately.)
- 5) Install cap and cap SFHCS and tighten to specified torque. (Cap and SFHCS ordered separately.)

UNIT DESCRIPTION	SEAL KIT NUMBER	PISTON SHCS (M12) HEX SIZE	TIGHTENING TORQUE		CAP SFHCS (M6) HEX SIZE	TIGHTENING TORQUE	
			in-lb	Nm		in-lb	Nm
PNC44/55	63098-01	10 mm	600	68	4 mm	85	9.5

Each kit contains:

- 1 Rod Seal
- 1 Piston Seal
- 1 Cap Seal
- 1 Bullet

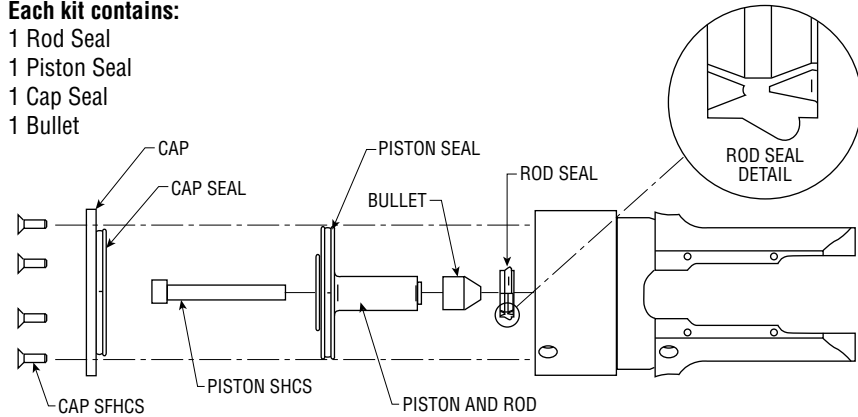

For additional technical assistance, call or visit our website:
 P.O. Box 9070, Fort Wayne, IN 46899
1-800-624-8511
phd,inc. www.phdinc.com

phd[®] SERIES PNC44/55 CLAMP TIP KIT

FOR USE WITH 1/8" CHARACTERS (SERIES 63100)

UNIT DESCRIPTION	PANEL THICKNESS	ANVIL COLOR	ANVIL KIT NO.	BACKER KIT NO.	RETAINER KIT NO.	ANVIL & BACKER KIT NO.	ANVIL, BACKER, & RETAINER KIT NO.	TIP SHCS M6 HEX	TIGHTENING TORQUE		RETAINER SHCS M6 HEX	TIGHTENING TORQUE	
									in-lb	Nm		in-lb	Nm
PNC44/55	0-1 mm	BLACK	65500-01			63130-01	63140-01	5 mm	125	14.1	5 mm	125	14.1
	1-2 mm	SILVER	65500-02	63120-09	63110-09	63130-02	63140-02						
	2-3 mm	GOLD	65500-03			63130-03	63140-03						

FOR USE WITH 3/16" CHARACTERS (SERIES 65300)

UNIT DESCRIPTION	PANEL THICKNESS	ANVIL COLOR	ANVIL KIT NO.	BACKER KIT NO.	RETAINER KIT NO.	ANVIL & BACKER KIT NO.	ANVIL, BACKER, & RETAINER KIT NO.	TIP SHCS M6 HEX	TIGHTENING TORQUE		RETAINER SHCS M6 HEX	TIGHTENING TORQUE	
									in-lb	Nm		in-lb	Nm
PNC44/55	0-1 mm	BLACK	65500-01			65330-01	65340-01	5 mm	125	14.1	6 mm	125	14.1
	1-2 mm	SILVER	65500-02	65320-08	65310-08	65330-02	65340-02						
	2-3 mm	GOLD	65500-03			65330-03	65340-03						

JAW TIP MOUNTING - JAW A

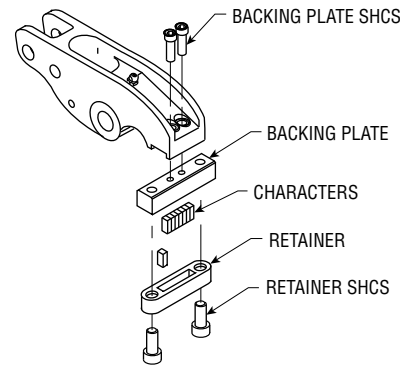

JAW TIP MOUNTING - JAW B

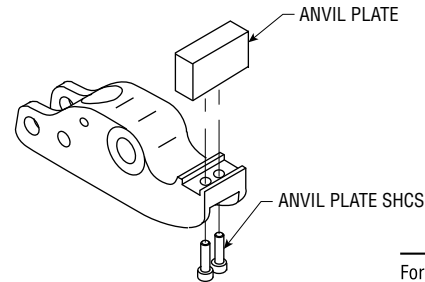

PNC44/55 TIP KITS	STANDARD MOUNTING
ANVIL KITS	1 Anvil Assembly 2 SHCS
RETAINER KITS	1 Retainer 2 SHCS
BACKER KITS	1 Backer Assembly 4 SHCS
ANVIL & BACKER KITS	1 Anvil Assembly 1 Backer Assembly 6 SHCS
ANVIL, BACKER, & RETAINER KITS	1 Anvil Assembly 1 Backer Assembly 1 Retainer 6 SHCS

For additional technical assistance, call or visit our website:
 P.O. Box 9070, Fort Wayne, IN 46899
1-800-624-8511
phd,inc. www.phdinc.com